



**VALVE REGULATED
LEAD ACID BATTERY (V.R.L.A.)**



**ADVANCED ABSORBED GLASS
MAT TECHNOLOGY (A.G.M.)**



**LONG DURATION BATTERIES
DESIGNED FOR MAXIMUM LIFE**

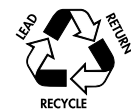

Features

- Flame-retardant polypropylene case and cover compliant with UL94 V-0 with an Oxygen Limiting Index of greater than 28%.
- Gas recombination greater than 99%.
- Operates at a low internal pressure.
- Never needs watering, minimal maintenance.
- 99.7% pure lead, calcium alloy grids.
- Shock absorbent thick wall polypropylene cases.
- Cold forged non-porous terminal bushings, eliminate post leakage.
- Thermally welded case to cover bond, eliminates both acid and electrical leaks.
- Over-sized, through the partition inter-cell welds provide low resistance connections, with minimal power loss.
- Flame arresting, low pressure safety release venting system for individual cells, recognized per U.L. 924.
- Measured high vacuum acid fill, reduces electrical variability between cells.
- 100% recyclable materials.

Options

- Terminal covers.
- Inter-connecting battery cables.
- Custom wire harnesses.

Specifications

Cells per unit	1
Nominal voltage	2
Terminal type	Copper insert 5/16"
Short circuit current	10952 amps
Impedance @ 77°F 25°C	0.21 milliohms
Weight lbs / kgs	81.9 / 37.1
Electrolyte (S.G.)	1.300
Capacity @ 77°F (25°C)	443 AH (8 hrs) to 1.75 V.P.C.
Ideal operating temperature range	+68°F (+20°C) to +77°F (+25°C)
Extended operating temperature range	Discharge: -40°F (-40°C) to +140°F (+60°C) Charge: -4°F (-20°C) to +122°F (+50°C)
Float Voltage	2.25 to 2.30 @ 77°F (25°C)
Recommended maximum charging current	C/4 amperes at 100% discharge Unlimited at partial discharge.
AC ripple from charging source	1.5% peak to peak of float
Storage period without recharge	6 months at 77°F (25°C)

No transport restrictions

- Surface transport. Classified as non-hazardous material as relates to DOT-CFR Title 49 part 171-189.
- Maritime transport. Non hazardous as per IMDG amendment 27.
- Air transport. Non hazardous complies with IATA / ICAO, special provision A67.

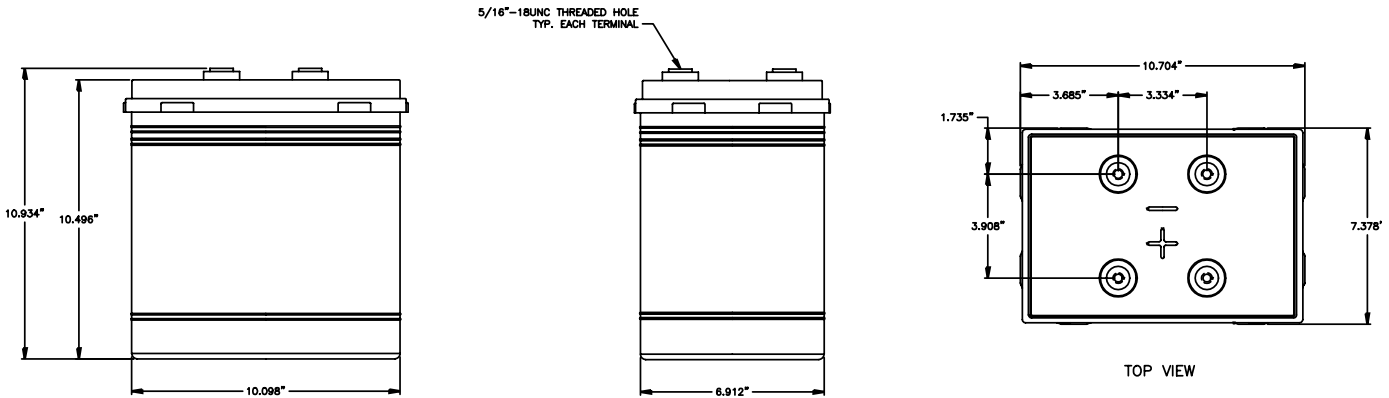

POWER BATTERY offers an extensive line of pre-wired and fused battery cabinets complete with UL and CUL approval. Standard and custom DC voltages complete with breakers and chargers are available.

Battery Cabinet Systems (pre-wired with TC-2550S batteries)							
Battery cabinet model	Maximum # of batteries	Dimensions					
		inches			millimeters		
		H	W	D	H	W	D
KS6	4	17.75	16.0	34.5	451	406	876
KS7	8	37.25	16.0	34.5	946	406	876
CR1	12	43.00	24.0	32.5	1092	610	826
CR3	20	43.00	40.0	32.5	1092	1016	826
CR6	30	60.00	40.0	32.5	1524	1016	826
CR4	40	77.00	40.0	32.5	1956	1016	826
CR5	48	77.00	48.0	32.5	1956	1219	826

Hours discharge rates in constant current (Amperes) and constant power (Watts) @ 77°F (25°C)														
Volts per cell		1	2	3	4	5	6	7	8	9	10	12	24	48
1.75	Amps	337	193	136	104	84.1	71.2	62.1	55.4	50.2	46.0	39.5	21.7	11.8
	Watts	647	356	248	192	158	134	117	104	93.0	85.0	72.0	39.0	21.0
1.80	Amps	317	187	133	101	81.9	69.4	60.5	54.0	49.0	44.9	38.6	21.3	11.6
	Watts	616	340	238	185	152	129	113	100	90.0	82.0	70.0	38.0	20.4
1.85	Amps	292	178	127	97.6	78.6	66.0	57.5	51.3	46.4	42.4	36.3	19.9	10.8
	Watts	577	324	229	178	146	124	108	96.0	87.0	79.0	67.0	36.0	19.4
1.90	Amps	261	156	110	87.0	72.3	62.1	54.5	48.9	44.2	40.4	34.7	19.0	10.3
	Watts	522	293	203	157	128	109	95.0	85.0	76.0	69.0	59.0	32.0	17.2

1343-2-0205
U.S.A.
Power Battery Company, Inc.
 25 McLean Blvd.
 Paterson, N.J. 07514-1507
 Phone: (973) 523-8630
 Fax: (973) 523-3023
 E-mail: sales@powbat.com
 Website www.powerbattery.com

CANADA
Power Battery (Iberville) Ltd.
 770 Thomas Ave.
 Iberville, Québec, J2X 5E7
 Phone: (450) 346-3273
 Fax: (450) 346-8003
 E-mail: powerbat@sympatico.ca
 Website: www.powerbattery.com

UK
Power Batteries Ltd.
 Premier Way, Abbey Park Industrial Estate
 Romsey, Hampshire, SO51 9AQ
 Phone: +44 (0)1794 835900
 Fax: +44 (0)1794 835910
 E-mail: sales@powbat.co.uk
 Website: www.powbat.co.uk

ITALY
Power Battery Srl
 Via Locatelli 105
 20046 Biassono MI - ITALY
 Phone: +(39) 039 2324571
 Fax: +(39) 039 2499200
 E-mail: calberti@powbat.it
 Website: www.powbat.it

CHINA
Power Battery (PACIFIC RIM) Ltd.
 Unit 1, 23/floor, Wealthy Plaza
 138 Sau Kei Wan Road
 Sai Wan Ho, Hong Kong
 Phone: ++(852) 2-560-2222
 Fax: ++(852) 2-967-8157
 E-mail: bplhk@netvigator.com
 Website: www.powerbattery.com